



Installation & Operation Manual



Download
Manual



Growatt New Energy

Shenzhen Growatt New Energy Technology CO.,LTD
No.28 Guangming Road, Shiyan Street, Bao'an District,
Shenzhen, P.R.China

T +86 0755 2747 1942

E service@ginverter.com

W www.ginverter.com

GR-UM-158-A-01

List

1 Brief Introduction

- 1.1 Preface
- 1.2 Target Group
- 1.3 Product Description
- 1.4 Safety Instructions

2 Safety

- 2.1 Purpose Use
- 2.2 Safety Measure
- 2.3 Symbols introduction on the SPH inverter

3 Product Description

- 3.1 Growatt SPH series inverter
- 3.2 Label Explanation
- 3.3 Size and weight
- 3.4 The advantage of the unit of Growatt SPH

4 Unpacking

5 Installation

- 5.1 Basic installation requirements
- 5.2 Installation requires tools and RJ 45 terminal sequence of the LAN line
- 5.3 Installation Instructions
- 5.4 SPH System Connection Mode

6 Commissioning

- 6.1 Commissioning of SPH
- 6.2 Operation modes
- 6.3 Country setting
- 6.4 Display and button
- 6.5 Communication

7 Start-up and shut down SPH system

- 7.1 Start-up the SPH system
- 7.2 Disconnect the SPH system

8 Attention of the installation environment, maintenance and cleaning

9 Fault removal

10 EU Declaration of Conformity

11 Decommissioning

- 11.1 Dismantling the energy storage
- 11.2 Packing the SPH inverter
- 11.3 Storing SPH inverter
- 11.4 Disposing of the SPH inverter

12 Product specification

- 14.1 Growatt SPH series energy storage machine product specification
- 14.2 DC input terminal parameter
- 14.3 Torque
- 14.4 Appendix

13 Certificate

14 Contact

1 Brief Introduction

1.1 Preface

This manual will provide the users who use the Growatt SPH TL3 BH Series of Shenzhen Growatt New Energy Technology Co.,LTD(Short for Growatt as below) with the detailed product information and the installation instructions. Please read this manual carefully and put this manual on some place where is convenient to installation, operation, obtain. Any modifications of Growatt new energy, we will not notify the user.

1.2 Target Group

Growatt SPH TL3 BH inverter must be installed by professional electrical personnel who have obtained the certification of the relevant departments. We have two kinds of energy storage machine for different battery one is for lithium battery and the other is for lead-acid battery, we suggest: customer should decide which kind of energy storage machine you want, Growatt can provide only lithium battery with energy storage machine, customer can choose lead-acid energy storage machine with no battery provide by Growatt while they can buy these battery from market easily. Especially if customer choose energy storage system with lithium battery(which must be provide by Growatt) but used for lead-acid battery or used lead-acid battery for lithium battery model, it will be dangerous. Installer can install energy storage machine of Growatt SPH TL3 BH Series rapidly and troubleshooting, build communication system through read this manual carefully.If you have any questions in the process of installation, you can login in www.growatt.com and leave some message.Or you can call our 24-hour service hotline+86 0755 2747 1942.

1.3 Additional information

Growatt SPH TL3 BH Series is used to store energy generated by the photovoltaic cell panels or energy from grid if it is allowed in the battery, also energy can be sent to power grid through SPH TL3 BH for self consumption or when Grid power is lost, SPH TL3 BH can be used as backup power.

SPH series has six kinds of type:

- SPH 4000TL3 BH
- SPH 5000TL3 BH
- SPH 6000TL3 BH
- SPH 7000TL3 BH
- SPH 8000TL3 BH
- SPH 10000TL3 BH

Note: we describe this series as "SPH" as below.

Overview:

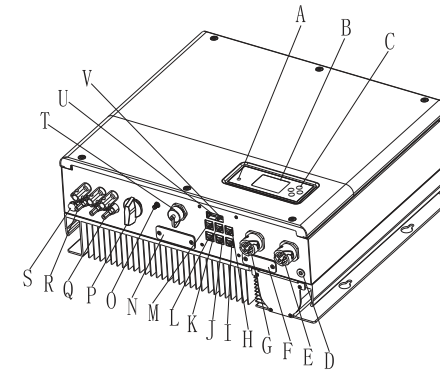

Chart 1.1

Position	Description
A	LED of status display
B	LCD screen
C	Function button
D	Ground point
E	EPS output(off grid connection)
F	RSD(do not open except by Professional staff)
G	AC Grid (on grid connection)
H	Rj45 interface of DRMs(used only in Australia)
I	NTC: Lead-acid temperature sensor terminal
J	RS485 communication interface of meter2(Reserved)
K	RS485 communication interface of Lithium battery
L	Rs485 communication interface of meter1
M	CAN communication interface of Lithium battery
N	RS232/Wi-Fi/shinelink cover board
O	Antenna
P	PV switch
Q	PV input
R	Battery terminal
S	Breathable valve
T	USB interface
U	DIP switch(set safety standard)
V	Dry contact

1.4 Safety Instructions

1. Please be clear which kind of battery system you want, lithium battery system or lead-acid battery system, if you choose the wrong system, SPH can't work normally.
2. Please read this manual carefully before the installation, The company has the right not to quality assurance, If not according to the instructions of this manual for installation and cause equipment damage.
3. All the operation and connection please professional electrical or mechanical engineer.
4. During installation, Please don't touch the other parts within the box.
5. All the electrical installation must comply with the local electrical safety standards.
6. If equipments needs to maintain, Please contact with local specify system installation and maintenance personnel.
7. Use the equipment to combined to grid needs to obtain the permission of local power supply department.
8. When install PV modules in the daytime, please turn off the PV switch, Otherwise it will be dangerous as high terminal voltage of modules in the sunshine.

2 Safety

2.1 Purpose Use

The system chart of SPH:

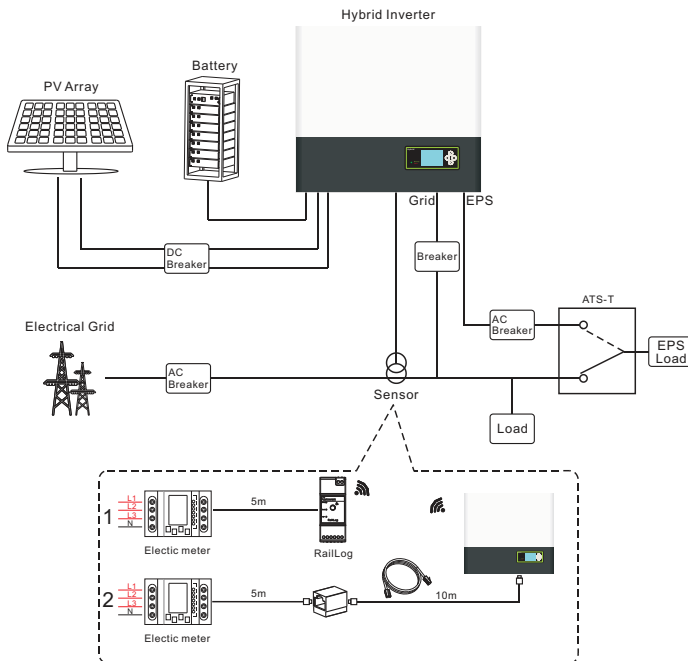

Chart 2.1

As shown above, a complete grid-connected system of SPH consists of PV modules, SPH inverter, battery, utility grid and other components.

Attention:

As the system refer to battery use, We must make sure ventilation of the service environment and temperature control in order to prevent the danger of battery explosion, Battery recommended installation environment must be strictly in accordance with the specification, if the specification is IP20 environment, the pollution degree of the unit is PD2, meanwhile the temperature should be control in the 0-40°C of indoor ventilation and the humidity should be 5%-85%. If the chosen PV modules needs to positive or negative ground connection, please contact with Growatt for technical support before installation.

2.2 Safety Measure



Risk of high voltage!
Relevant operation for professional personnel.
Please notice children, disabled, laypeople do not close.
Supervise and make sure children don't play near the installation position of energy storage machine.



Risk of burns on the parts shell of SPH inverter!
During the work, Cover, shell around, radiator is likely to be hot.



SPH inverter exists radiation maybe affect health!
Don't stay a long time within 20cm range from SPH inverter.









SPH inverter ground connection

Please ensure SPH inverter ground connection is reliable for make sure people's safety.

2.3 Symbols introduction on the SPH inverter

Symbol	Description
	Caution: Risk of electrical shock!
	Caution : hot surface!

	Caution: risk of danger!
	Danger to life due to high voltage in SPH. There is residual voltage in SPH, SPH requires 5 minutes to discharge. Please wait 5 minutes before you open the upper lid or the DC lid.
	Protective conductor terminal
	Direct Current(DC)
	Alternating Current(AC)
	The machine complies with the requirements of the applicable CE guidelines
	Refer to the operating instructions.

3 Product Description

3.1 Growatt SPH series inverter

Marks of SPH

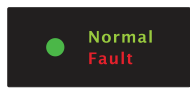
Mark	Description	Explanation	
	Push-button	Operation of display screen and set system	
	Status symbol of SPH	Green light on	SPH run normally
		Red light on	fault state
		Green light blinking	Alarm state
		Red light blinking	Software updating

3.2 Label Explanation

Label contains the following information: for example SPH 10000TL3 BH shows as below:

Growatt Hybrid Inverter	
Model name	SPH 10000TL3 BH
PV input data	
Max. PV voltage	1000 d.c.V
PV voltage range	160-1000 d.c.V
PV Isc	15 d.c.A*2
Max. input current	12 d.c.A*2
AC output/input data	
Nominal input/output power	10000/10000 W
Max. output apparent power	10000 VA
Nominal voltage	3W/N/PE 230/400 a.c.V
Max. input/output current	15/15 a.c.A
Nominal Frequency	50/60 Hz
Power factor range	0.8leading~0.8lagging
Stand alone data	
Nominal AC output power	6000 W
Nominal AC output voltage	230/400 a.c.V
Nominal AC output Frequency	50/60 Hz
Battery data	
Battery voltage range	160-550 d.c.V
Max. charging and discharging current	20 d.c.A
Type of battery	Lithium / Lead-acid
Others	
Safety level	Class I
Ingress Protection	IP65
Operation Ambient Temperature	-25°C - +60°C
 Made in China	

Description of label:

The type of product	Growatt SPH 10000TL3 BH
PV input data	
Max. PV voltage	1000Vdc
PV voltage range	160~1000Vdc
PV Isc	15A*2
Max. input current	12A*2
AC output/input data	
Max. output power	10000W
Max. apparent power	10000VA
Nominal output voltage	3W/N/PE 230/400Vac
Max output current	15A
Nominal output Frequency	50Hz/60Hz
Power factor range	0.8 leading~0.8 lagging
Stand alone data	
Nominal AC output power	6000W
Nominal AC output voltage	230/400Vac
Nominal AC output Frequency	50Hz/60Hz
Battery data	
Battery voltage range	160~550Vdc
Max. charge and discharge current	20A
Type of battery	Lithium / Lead-acid
Others	
Safety level	Class I
Ingress Protection	IP65
Operation Ambient Temperature	-25°C~+60°C
Certificates Number	(For Australian models)

3.3 Size and weight

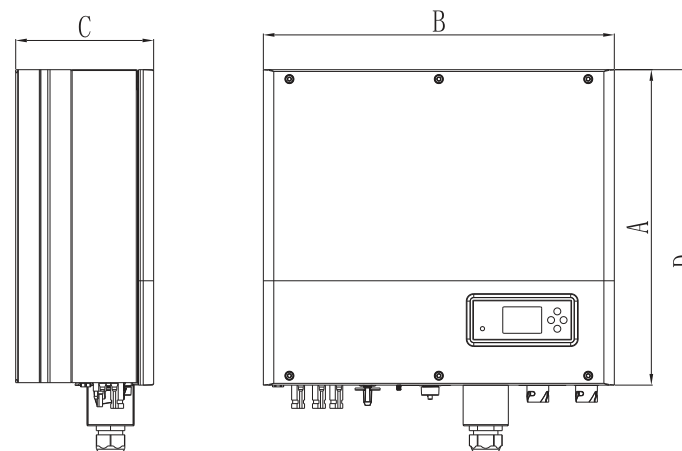

Chart 3.1

	A(mm)	B(mm)	C(mm)	weight(kg)
Growatt SPH TL3 BH	453	505	198	28

3.4 The advantage of the unit of Growatt SPH

Features below:

- All in one design. Can improve self consumption, back up and also pinch the valley.
- Smart management, work mode can be set.
- Safe battery used.
- Easy installation.
- Two mpp tracker input.

4 Unpacking and inspection

Please check whether external damage to the goods before unpacking. After unpacking, Please check whether the unit damage or missing parts, If it is happen, Please contact with supplier.
Growatt SPH series and accessories as follows:

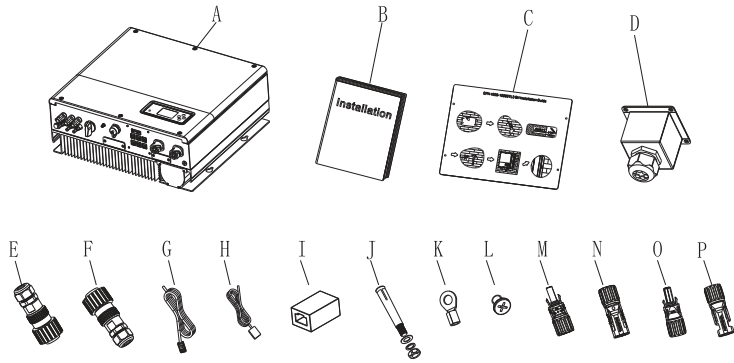

Chart 4.1

Item	Number	Description
A	1	SPH inverter
B	1	User Manual
C	1	Paper board(installation guide)
D	1	Waterproof cover
E	1	AC Grid connector
F	1	EPS output connector (red connector)
G	1	Communication cable
H	1	Lead-acid battery temperature sensor
I	1	RJ45 connector
J	4	M6 setscrew
K	1	Ground terminal
L	4	M4 setscrew
M/N	2/2	Mc4 connector(black connector)
O/P	1/1	Mc4 connector (blue connector)

Installation 5

5.1 Basic installation requirements

- A. The installation location must be suitable for SPH's weight for a long period time.
- B. The installation location must conforms with dimension of SPH.
- C. Do not install the unit on structures constructed of flammable or thermo labile materials.
- D. The Ingress Protection rate is IP65 and the pollution degree is PD2. Please refer to the below:

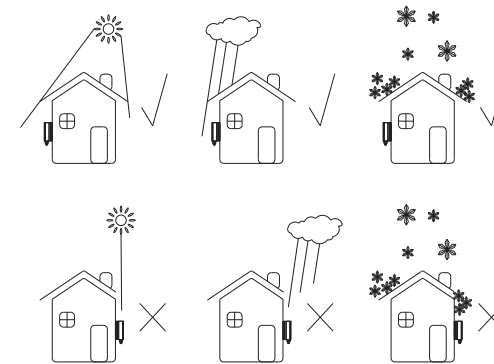

Chart 5.1

- E. Battery installation option is not far away from the position of SPH, the length between SPH and battery should not be more than 5m.
- F. The ambient temperature should be -25°C ~ 60°C.
- G. SPH can be installed in vertical or lean back on plane, Please refer to the below:

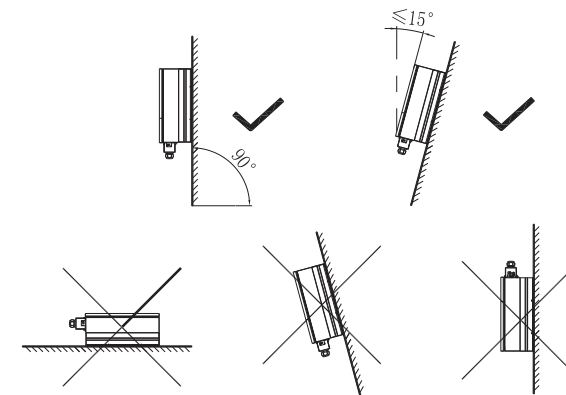

Chart 5.2

H. Installation position shall not prevent access to the disconnection means.
 I. In order to ensure machine can run normally and easy to operate, please pay attention to provide adequate space for SPH, Please refer to below:

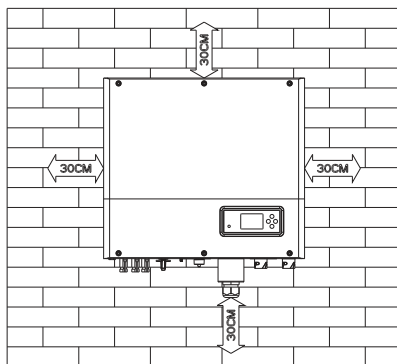

Chart 5.3

J. Do not install the machine near television antenna or any other antennas and antenna cables.
 K. Don't install the machine in the living area.
 L. Be sure that the machine is out of the children's reach.
 M. Taking the battery fixing space into account, about the dimensions please reference user manual.
 N. The Inflammable and explosive dangerous goods must not be placed around battery in case of cause serious danger.

5.2 Installation requires tools and RJ 45 terminal sequence of the LAN line.

When installing, we need to use tools as follow, prepare the follow tools before installing:



Chart 5.4

No.	Description
1	Press the RJ45 terminal
2	Press battery terminal connector
3	Disconnect PV terminal
4	Unscrew nut
5	Unscrew screw
6	Knock explosion bolt
7	Drill holes on the wall

LAN line RJ45 sequence as follow:

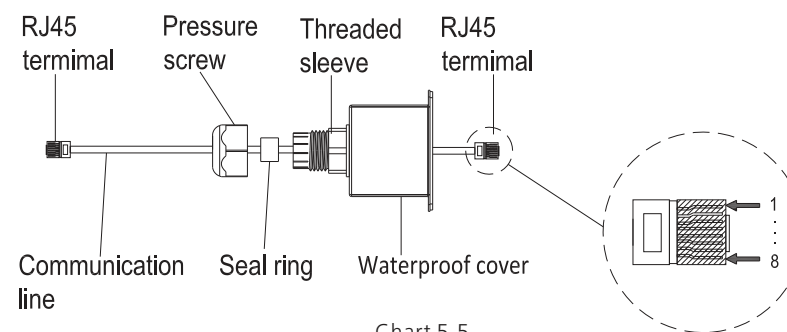

Chart 5.5



Chart 5.6

LAN line 1-8 colors as below:

PIN	1	2	3	4	5	6	7	8
Color	White orange	Orange	White green	Blue	White blue	green	White brown	brown

5.3 Installation Instructions

5.3.1 Attention Layout (length of sensors consider)

Only one type of sensors for use with Growatt SPH, can only use the meter sensor. Before installing you should know something that as below:

The cable of meter is suggested not longer than 15m. So you need to consider the length between SPH with combiner box for the sensor should be installed in the live line.

The installation layout of energy storage machine at home as following:

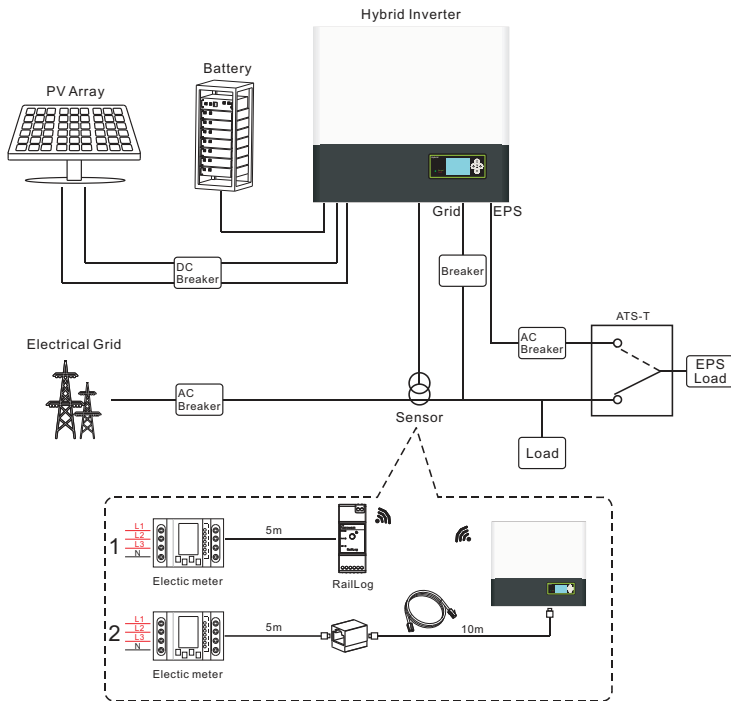

Chart 5.7

5.3.2 Installation of SPH

1. Project the machine's probably sizes on the wall; the thickness of wall for SPH must be not less than 60mm.

2. Make sure the drill position, use paper board(installation guide), put the paper board cling to the wall, make sure the top edge of paper board is level (As the chart 5.8a below).

3. Mark four points at the wall via the hole of the paper board, then remove the paper board.

4. Drill four $\Phi 8$ holes at the mark point, the depth is not less than 55mm.

5. Knock four explosion bolt into $\Phi 8$ holes (As the chart 5.8b below).

6. Hang the energy storage machine on the four setscrews (As the chart 5.8c below).

7. Lock the nut of setscrew (As the chart 5.8d below).

8. The whole installation has finished.

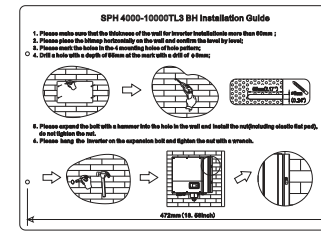

a)

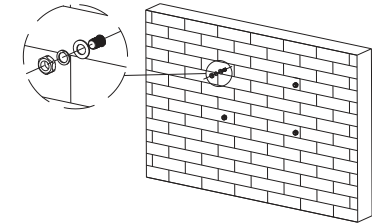

b)

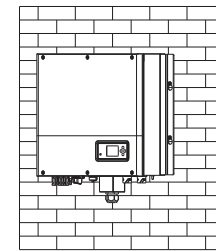

c)

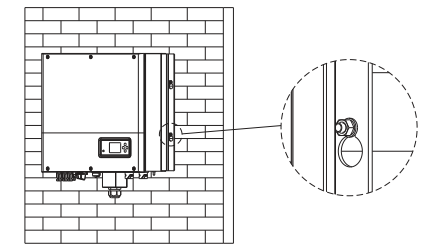

d)

Chart 5.8

5.4 SPH System Connection Mode

5.4.1 Connection of PV terminal

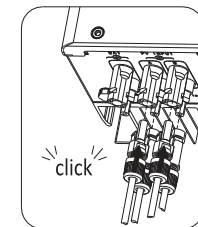
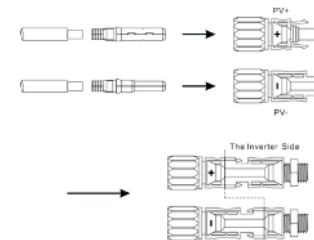

Chart 5.9

Similar to the traditional inverter connecting, the input of PV panel energy can be realized by using MC4 PV terminal, the detail steps are as follows:

Step 1: Turn off PV switch.

Step 2: Insert PV panel positive and negative cables into MC4 terminal, then connect positive pole(+) of connection cable to positive pole(+) of PV input connector, Connect negative pole(-) of connection cable to negative pole(-) of PV input connector.

Please pay attention to PV input voltage and current within permission Limit:

- Max PV voltage: 1000V (consider the lowest temperature)
- Max PV input current: 12A
- Max PV input power per string: 6500W.

Remark:

1. We suggest you use the cable $\geq 4\text{mm}^2/12\text{ AWG}$ to connect.
2. Please do not connect to DC source.

5.4.2 Connection of AC terminal and off grid terminal

SPH has a grid output terminal and off grid out terminal, look down on the SPH from the front, the terminal on the left (on grid) is grid outlet for connecting grid, the terminal on the right is an emergency power outlet for connecting critical load.

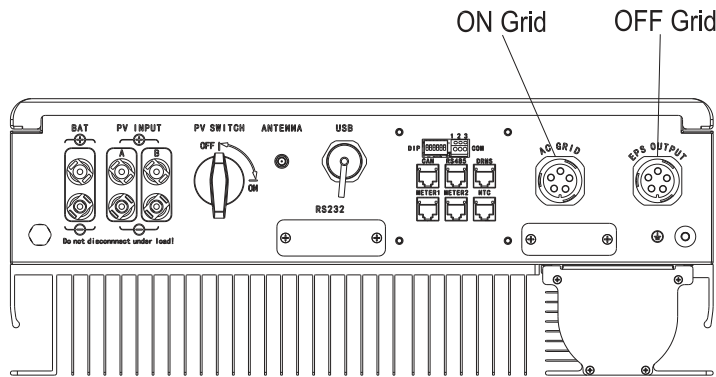

Chart 5.10

Wire suggest length:

conductor cross section	max cable length					
	Growatt SPH 4000 TL3 BH	Growatt SPH 5000 TL3 BH	Growatt SPH 6000 TL3 BH	Growatt SPH 7000 TL3 BH	Growatt SPH 8000 TL3 BH	Growatt SPH 10000 TL3 BH
5.2mm ² 10AWG	40m	33m	28m	26m	25m	23m
6.6mm ² 9AWG	50m	42m	36m	33m	32m	29m

AC output terminal and EPS output terminal connection steps as follow:

Step 1: Uninstall the AC terminal as below chart.

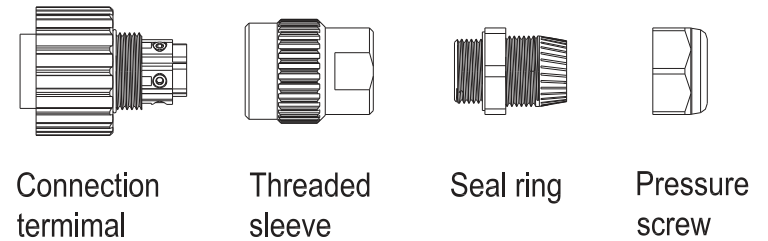

Chart 5.11

Step 2: Thread cables through pressure screw, seal ring, threaded sleeve in sequence, insert cables into connection terminal according to polarities indicates on it and tighten the screws.

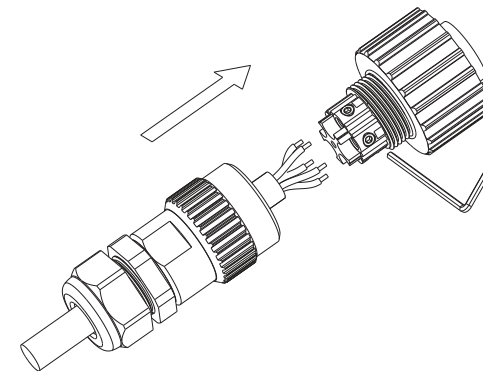

Chart 5.12

Step 3: Push threaded sleeve on to connection terminal until both are locked tightly.

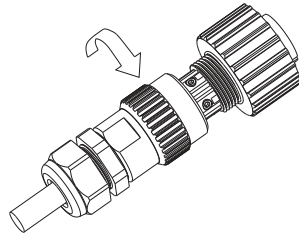
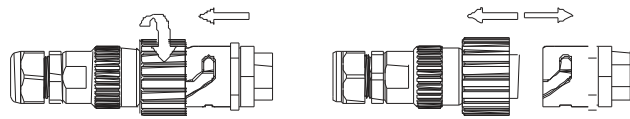

Chart 5.13

Step 4: Plug the socket into AC output terminal, clockwise rotation to tighten the socket, counterclockwise rotation to loosen the socket.



Screw up AC connector

Release AC connector

Chart 5.14

The following diagram shows the AC output terminal of the Australian machine connection steps, EPS output terminal connection steps consistent with the above steps.

AC output terminal and EPS output terminal connection steps as follow:

Step 1: Uninstall the AC terminal as below chart.

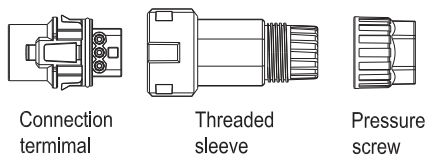

Connection terminal

Threaded sleeve

Pressure screw

Chart 5.15

Step 2: Thread cables through pressure screw, seal ring, threaded sleeve in sequence, insert cables into connection terminal according to polarities indicates on it and tighten the screws.

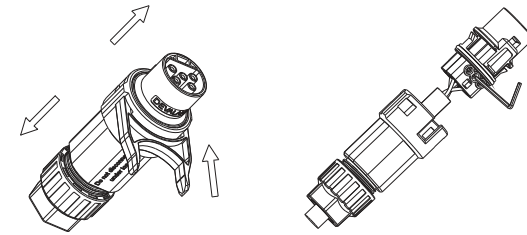

Chart 5.16

Step 3: Push threaded sleeve on to connection terminal until both are locked tightly.

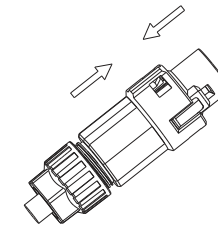
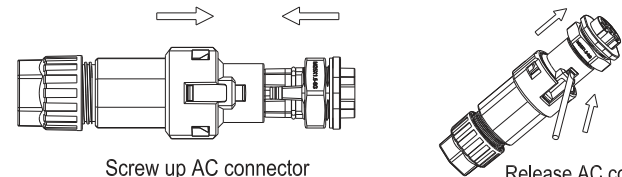

Chart 5.17

Step 4: Plug the socket into AC output terminal until it is locked. Use a flat-blade screwdriver to hold the buckle and pull out the AC terminal.



Screw up AC connector

Release AC connector

Chart 5.18

Step 5: Plug the AC terminal into the inverter AC port.

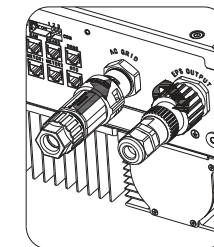

Chart 5.19

The recommended wiring diagram is as follows:

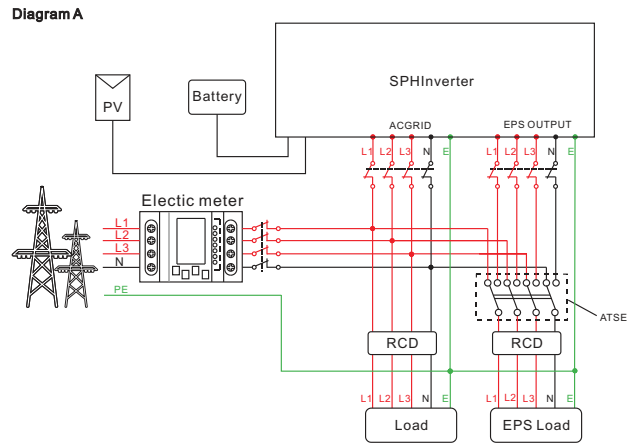

Chart 5.20

Note:
This diagram is an example for grid system without special requirement on electrical wiring connection.

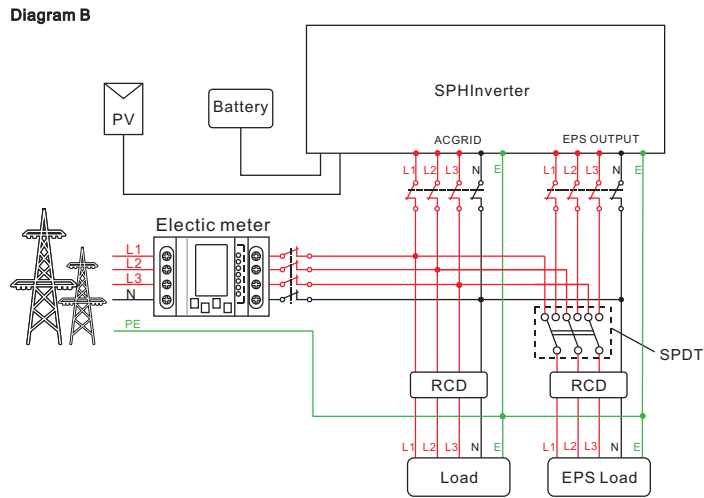

Chart 5.21

Note:
This diagram is an example for Australian and New Zealand grid system where neutral line can't be switched.

Diagram C

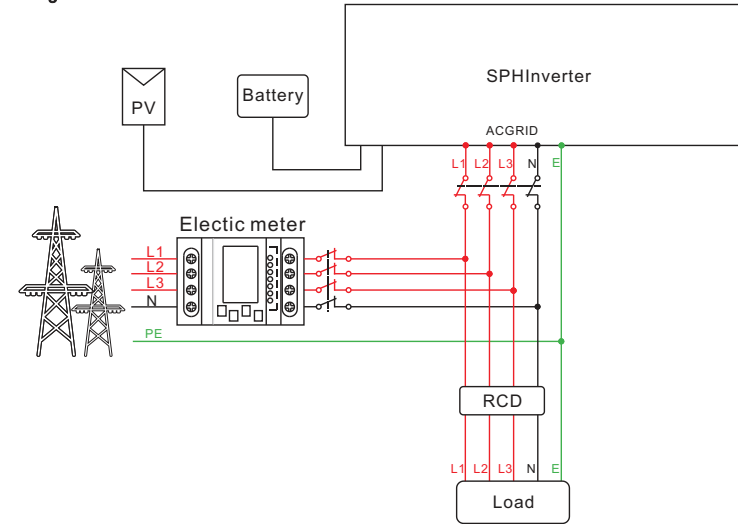

Chart 5.22

Note:
This diagram is an example for customer who only wants to use the on grid storage system.



Notice:

- If you want to use on grid only, please refer to chart 5.17 Connect with AC grid and float EPS OUTPUT.
- If you have no battery now, you can also float BAT terminal, and this hybrid inverter will only work like a PV inverter.
- If you want to use both on grid power and backup power, please refer to chart 5.15 and 5.16. Connect with AC grid and EPS OUTPUT like the chart show.
- On grid terminal and off grid terminal can't directly connect together.
- Off Grid terminal can't connect to grid.
- If you want to use on grid and off grid, you can use ATS (automatic transfer switch) like chart 5.15 and 5.16 before or ask Growatt for help to connect them.
- The first start of system needs Grid power.



EPS output does not support half-wave load type devices, such as hair dryers.

5.4.3 Connection of battery terminal

Similar to the traditional inverter connecting, the input of battery can be realized by using MC4 terminal, the detail steps are as follows:

Step 1: Turn off battery switch.

Step 2: Insert battery panel positive and negative cables into MC4 terminal, then connect positive pole(+) of connection cable to positive pole(+) of battery input connector, connect negative pole(-) of connection cable to negative pole(-) of battery input connector.

Please pay attention to battery input voltage and current within permission Limit:

- Max battery voltage: 550V
- Max battery input current: 20A
- Max battery input power : 10000W

Remark:

We suggest you use the cable $\geq 4\text{mm}^2/10\text{ AWG}$ to connect.

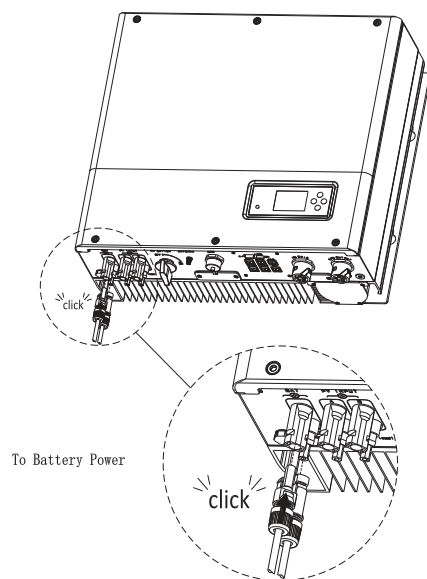

Chart 5.23

Note:

We suggest the distance between battery and SPH no longer than 5m, and The power line area must be larger than 12AWG.

5.4.4 Connection of meter terminal

When customer needs to use meter to monitor the energy flow, the meter terminal connection steps are as follows:

Step1: Reference 5.2, make LAN cables with RJ45 terminal.

Step2: Thread the swivel nut over the LAN cable.

Step3: Press the cable support sleeve out of the cable gland.

Step4: Remove the filler plug from the cable support sleeve.

Step5: Route the LAN cable through an opening in the cable support sleeve.

Step6: Thread the LAN cable through the cable gland.

Step7: Insert the RJ45 plug of the network cable into the "METER-1" pin connector on the inverter until it snaps into place.

Step8: If no other cables need to be installed, lock the waterproof cover to the inverter with screws.

Step9: Screw the swivel nut onto the waterproof cover.

Note:

1. Meter must be provided by Growatt. If not, maybe meter can't communicate with SPH inverter.

2. The more detail describe of meter installation, please turn to meter user manual.

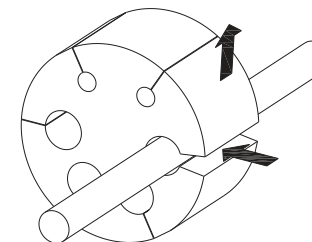

Chart 5.24

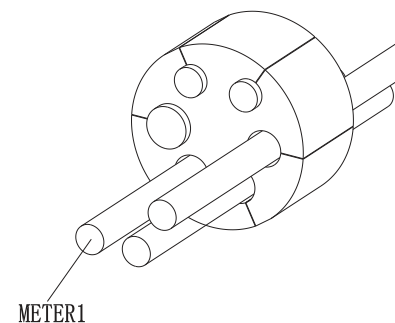

Chart 5.25

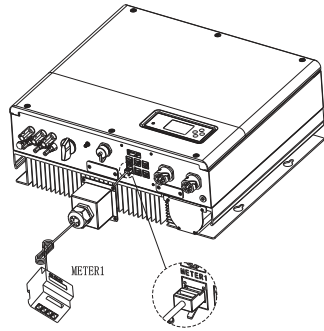

Chart 5.26

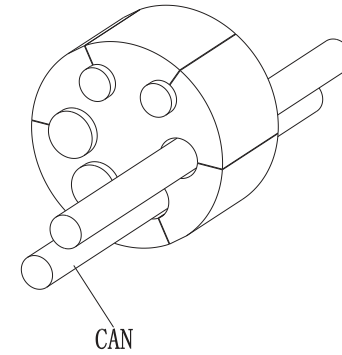

Chart 5.28

Remark:
 Meter wire (5m in length) specification: RJ45, standard LAN line (one end with 8P modular plug, the other connected with transformer). But if the length is not enough, customer can add cable, so the length can be increased to 15m max, the operation is as follow chart:

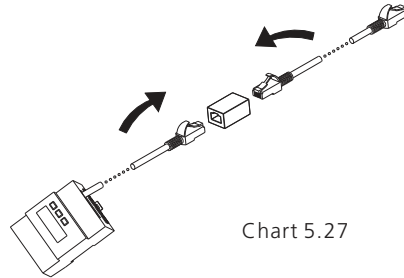

Chart 5.27

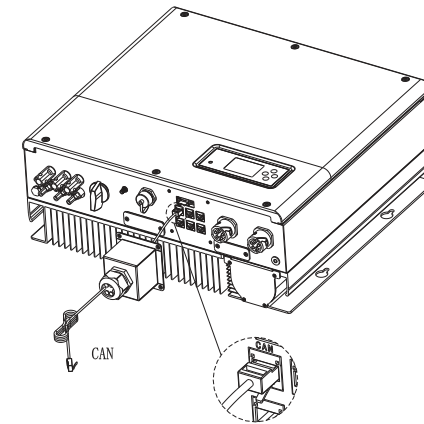

Chart 5.29

5.4.5 Connection of communication terminal for lithium battery (CAN)

When using CAN communication with lithium batteries (for example PYLONTECH X1) , connect lithium battery terminal (RJ45) steps as follows:

- Step1: Unscrew the swivel nut from the cable gland.
- Step2: Thread the swivel nut over the "CAN" cable.
- Step3: Press the cable support sleeve out of the cable gland.
- Step4: Remove the filler plug from the cable support sleeve.
- Step5: Route the "CAN" cable through an opening in the cable support sleeve.
- Step6: Thread the "CAN" cable through the cable gland.
- Step7: Insert the RJ45 plug of the network cable into the "CAN" pin connector on the inverter until it snaps into place.
- Step8: If no other cables need to be installed, lock the waterproof cover to the inverter with screws.
- Step9: Screw the swivel nut onto the waterproof cover.

Note:

- 1. If you are using a lead-acid battery, you do not need to install this communication cable.
- 2. The CAN battery communication and RS485 battery communication can't be installed at same time, please select the correct communication method according to the battery manual.
- 3. If the cable such as "RS485" cable or "CAN" cable is not used, please do not remove the filler plug from the cable support sleeve.

5.4.6 Connection of communication terminal for lithium battery (RS485)

When using lithium batteries which need to connect BMS system of the battery, connect lithium battery

terminal (RJ45) steps as follows:

Step1: Unscrew the swivel nut from the cable gland.

Step2: Thread the swivel nut over the "RS485" cable.

Step3: Press the cable support sleeve out of the cable gland.

Step4: Remove the filler plug from the cable support sleeve.

Step5: Route the "RS485" cable through an opening in the cable support sleeve.

Step6: Thread the "RS485" cable through the cable gland.

Step7: Insert the RJ45 plug of the network cable into the "RS485-2" pin connector on the inverter until it snaps into place.

Step8: If no other cables need to be installed, lock the waterproof cover to the inverter with screws.

Step9: Screw the swivel nut onto the waterproof cover.

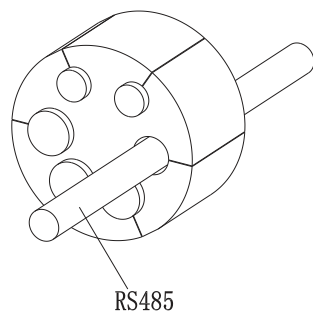

Chart 5.30

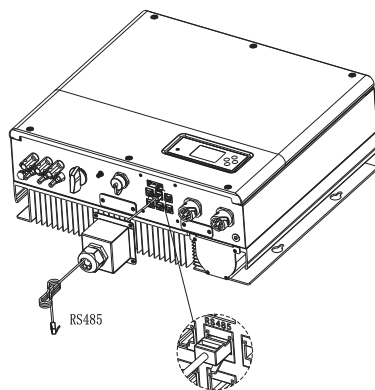

Chart 5.31

5.4.7 Connection of DRMS terminal(Australia only)

When SPH is applied to Australia, the DRMS terminals need to be connected, the connection way appears as follows:

Step1: Unscrew the swivel nut from the cable gland.

Step2: Thread the swivel nut over the "DRMS" cable.

Step3: Press the cable support sleeve out of the cable gland.

Step4: Remove the filler plug from the cable support sleeve.

Step5: Route the "DRMS" cable through an opening in the cable support sleeve.

Step6: Thread the "DRMS" cable through the cable gland.

Step7: Insert the RJ45 plug of the network cable into the "DRMS" pin connector on the inverter until it snaps into place.

Step8: If no other cables need to be installed, lock the waterproof cover to the inverter with screws.

Step9: Screw the swivel nut onto the waterproof cover.

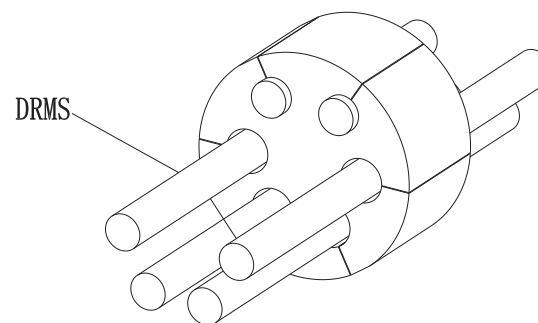

Chart 5.32

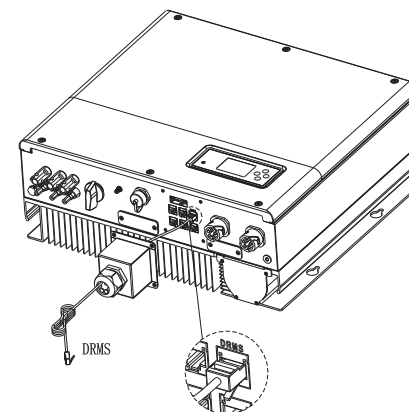

Chart 5.33

RJ45 terminal pin assignment

PIN	assignment for inverter scapable of both charging and discharging
1	DRM5
2	DRM6
3	DRM7
4	DRM8
5	RefGen
6	COM/DRM0
7	/
8	/

Method of asserting demand response modes

MODE	Rj45 socket asserted by shorting pins		Requirement
DRM0	5	6	operate the disconnection device
DRM5	1	5	Do not generate power
DRM6	2	5	Do not generate at more than 50% of rated power
DRM7	3	5	Do not generate at more than 75% of rated power and sink reactive power if capable
DRM8	4	5	Increase power generation (subject to constraints from other active DRMs)

Note:

If the cable such as "NTC" (lead-acid battery temperature sensor) cable is not used, please do not remove the filler plug from the cable support sleeve.

5.4.8 Connection of temperature probe for lead-acid battery

When customer using lead-acid battery, the temperature probe of the lead-acid battery is used to detect the ambient temperature of the lead-acid battery, the battery temperature cable of the SPH side connection steps are as follows:

Step1: Unscrew the swivel nut from the cable gland.

Step2: Thread the swivel nut over the "NTC" cable.

Step3: Press the cable support sleeve out of the cable gland.

Step4: Remove the filler plug from the cable support sleeve.

Step5: Route the "NTC" cable through a min opening in the cable support sleeve.

Step6: Thread the "NTC" cable through the cable gland.

Step7: Insert the RJ45 plug of the network cable into the "NTC" pin connector on the inverter until it snaps into place.

Step8: If no other cables need to be installed, lock the waterproof cover to the inverter with screws.

Step9: Screw the swivel nut onto the waterproof cover.

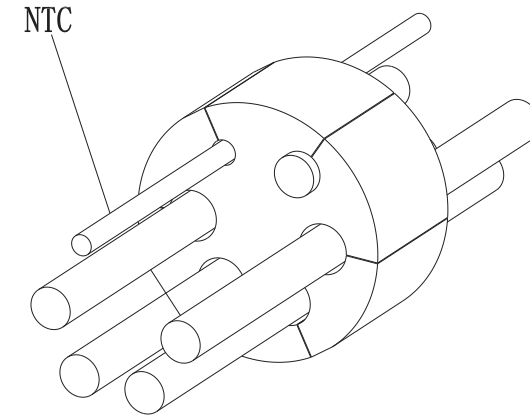

Chart 5.34

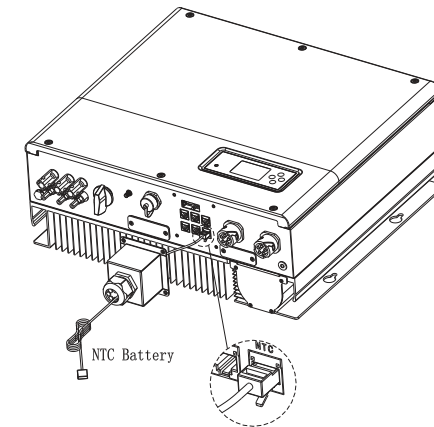

Chart 5.35

Note:

1. If you are using a lithium battery, you do not need to install this temperature probe, the probe of the temperature cable should be attached to the surrounding environment of the lead-acid battery, and the length of this cable is 1.5m, so pay attention to the distance of battery and SPH.
2. If the cable such as "NTC" (lead-acid battery temperature sensor) cable is not used, please do not remove the filler plug from the cable support sleeve.

5.4.9 Connection of Dry contact

The dry contact is used to communicate with external devices (such as remote start hot water heater). The wiring steps are as follows:
 Step1: Unscrew the swivel nut from the cable gland.
 Step2: Thread the swivel nut over the cable.
 Step3: Press the cable support sleeve out of the cable gland.
 Step4: Remove the filler plug from the cable support sleeve.
 Step5: Route the network cable through an opening in the cable support sleeve.
 Step6: Thread the network cable through the cable gland.
 Step7: Thread cables into connection terminal of the inverter, then press the terminal by relevant tools and make sure cables are firmly.
 Step8: If no other cables need to be installed, lock the waterproof cover to the inverter with screws.
 Step9: Screw the swivel nut onto the waterproof cover.

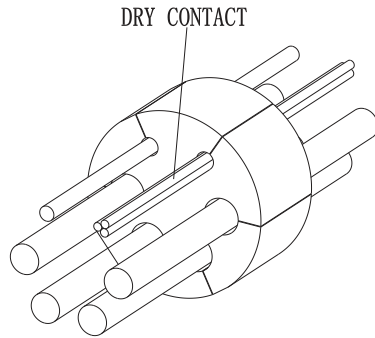

Chart 5.36

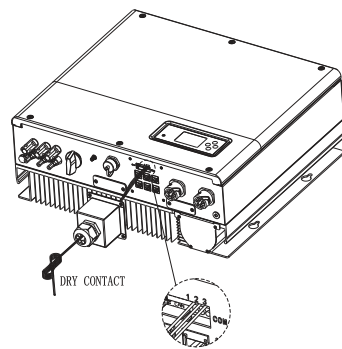

Chart 5.37

Note:
 If the cable such as "Dry contact" cable is not used, please do not remove the filler plug from the cable support sleeve.

5.4.10 Grounding connection

SPH must be grounded by cable, the grounding point is showed as follow, and the minimum grounding cable wire diameter is 10.0mm².

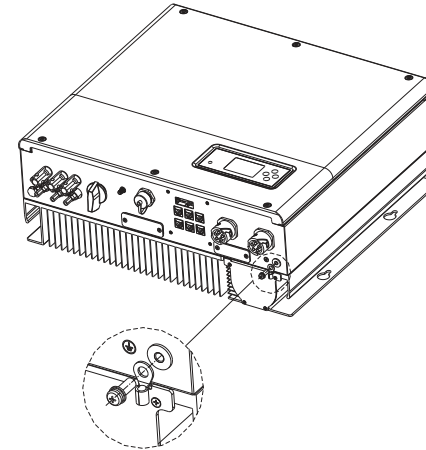

Chart 5.38

PV Array Grounding

Grounding conductor of PV panel brackets must be firmly connected to earth at PV array side and inverter side and SP side. The sectional area of grounding conductor should be equal to the sectional area of DC grounding conductor. The minimum wire diameter is 10.0mm².

DC Grounding

Select the DC Grounding mode according to the local standard and use the PV grounding terminal box and DC Grounding wires of the same specification.

Grounding Device

If the positive pole or the negative pole of PV array need to be grounded in the PV system, the inverter output should be insulated by Isolation Transformer. Isolation transformer must conform to IEC62109-1,-2 standard.

Connection as below:

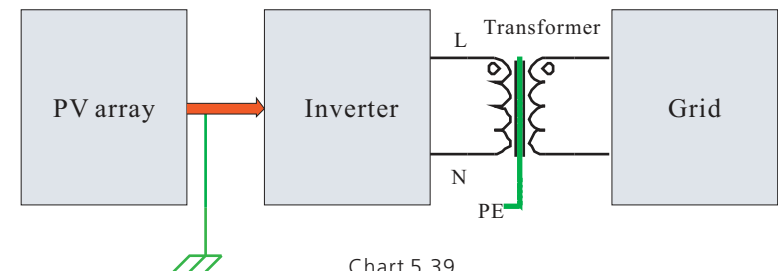

Chart 5.39

6 Commissioning

6.1 Commissioning of SPH

Electrify SPH after all installation of Part5 be finished, here are the steps:

- Connect PV
- Connect AC
- Connect battery
- Turn on AC first
- Then turn on battery
- Last turn on PV

If PV Grid and battery are available, system would work on the "normal" mode. When the SPH on the normal mode, the screen showing "normal", LED is green, if SPH not enter normal mode successful, especially the LCD is red, you need to check below:

- Make sure all the connection is correct.
- All the external switches are on.
- Inverter built -in switch is on.
- Make sure the lithium battery is on.
- Refer to Part 9.1 for correction.

You can refer to Part 6.3.4 for work mode setting, then configure monitor, finish commissioning.

6.2 Operation modes

6.2.1 Normal mode

Normal mode is working state which including online mode and backup mode.

- **Online mode**

User can set an appropriate priority mode according to request when SPH working on the online mode. If customer uses the LCD and key settings, you can only set one period, but if you use website settings, you can set up to three periods of the priority mode. (Refer to 6.3.4)

Load first: load first is the default mode, when it's working in this mode, PV energy would offer to load and battery prior; when PV is insufficient, battery would discharge; when PV is sufficient for load, the excess energy would feed to battery. If there is no battery or battery is full, the excess energy would feed to Grid(except anti -reflux).

Battery first: when SPH working in this mode, battery would be charged first, it's suitable working on the period when the electric charge is low. user need to set the mode ON and OFF time, and the end time of battery SOC. Users can set power rate which less than the battery maximum output power. If the customer doesn't enable the AC CHG (AC grid charging functions). Inverter will charge battery by PV power as large as it can do. If the customer enables the AC CHG (AC grid charging functions). Inverter will charge battery by PV power and AC power from grid as large as it can do.

Grid first: when SPH working in Grid-first mode, the PV energy would feed to Grid first. User can choose the period when electric charge is high. User need to set the mode ON and OFF time, and the end time of battery SOC. user can set power rate which less than the battery maximum output power.

- **Backup mode**

If Grid lost, system would turn to backup mode (user can disable it, refer to 6.3.4) and AC output from EPS LOAD port, all the energy from PV and battery, if the PV also lost, then only battery discharge. Mind you, SPH maximum output power is 6000W in this mode, the load which connect with EPS LOAD should less than 6000W.

NOTICE:

User only can set one period for battery first and Grid first on the LCD, if user need set more please login shineserver.

If user needs Grid charge battery, user need input password on the SC surface and set the AC CHG to enable.

6.2.2 Fault mode

The SPH's intelligent control system could monitor and adjustment system's status continuously, when SPH inverter monitoring anything unexpected happen, such as system fault or machine fault ,the LCD will display the fault information, in fault mode, the LED light will be lighten.

NOTICE:

- The detail's fault information please refer to 9.1
- Some fault information is in order to remind users that might have some faults occurred in inverter side.

6.2.3 Programming mode

Programming mode indicates the SPH is updating, don't cut out power when it's updating until the processing is finish, SPH inverter would log out automatically when the updating finish and turn to other mode.

6.2.4 Checking mode

Before SPH work in normal mode, it will go to self-check mode. If all are ok, system will go to normal mode, otherwise, it will go to fault mode.

6.2.5 Standby mode

If the system hasn't faults while the condition is not qualified, SPH would stay at standby mode.

6.2.6 Shutdown mode

If customer need SPH inverter stop working, customer must disconnect all the energy source, then SPH inverter will turn into shutdown mode automatically. The following is the shutdown procedure:

- Shutdown the PV side
- Turn off battery switch.
- Shut down AC power of SPH. Then you can see the both LED and LCD of SP are off.

NOTICE:

After all the actions are done, you still have to wait for more than 5 minutes.

6.3 Country setting

Growatt can provide various regulations of the machine, after customers receive the machine, according to their country, by dialing DIP switch to set the corresponding regulations. Following is the DIP switch introduction.

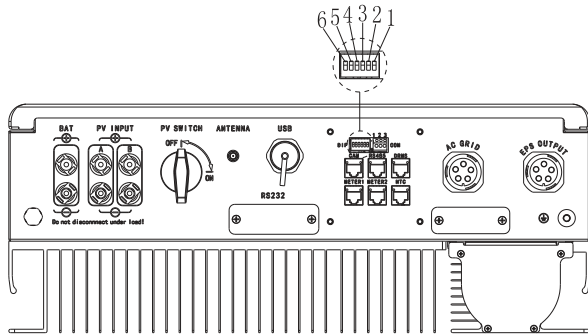

Chart 6.1

<p>DANGER</p>	<p>Caution : When you setting the DIP, you must turn off PV switch, AC breaker and Battery to make sure all of the power are off.</p>
	<p>Caution: 1. After setting the DIP, please power on the inverter and check the model display (show as 6.3.1). If the model display is match what you want, it means your setting is successful. 2. You need to calibrate the time that the machine is showing after inverter starts up. If the country is set incorrectly, please shut down the inverter and set again.</p>

The DIP switch is composed of five-digit binary number PINS. The different combination of the five PINS can represent different inverter's model, which is corresponding to the local grid standard. Each small white PIN has two statuses, when set upward to "ON", its value turns to "1", when set downward, its value turns to "0". Concerning the matching of the PIN status and the country safety standard, please refer to the table below:

6.3.1 Switch to country table

DIP switch status	Country/region / regulations	Model display
	VDE 0126	GT0XXXXXX1
	Queensland	GT0XXXXXX2
	As4777	GT0XXXXXX3
	CEI 0-21	GT0XXXXXX4
	G98	GT0XXXXXX5
	Greece	GT0XXXXXX6
	VDE-AR-N 4105	GT0XXXXXX7

	Thailand MEA	GT0XXXXXXE
	Thailand PEA	GT0XXXXXXF
	Spain	GT1XXXXXX0
	CQC-1	GT1XXXXXX1
	TAIWAN	GT1XXXXXX2
	EN50438-Ireland	GT1XXXXXX3
	TUV000	GT1XXXXXX4

	Brazil	GT1XXXXXX5
	EN50438-Sweden	GT1XXXXXX6
	Denmark	GT1XXXXXX7
	AS4777-NEW Zealand	GT1XXXXXX8
	France	GT1XXXXXX9

6.4 Display and button

6.4.1 LCD display area

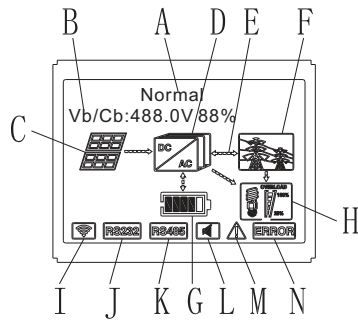

Chart 6.2

Location	Description
A	State
B	Information
C	PV input (if you connect two tracks, it will show two. Otherwise show one)
D	SPH inverter
E	Power flow line
F	Grid
G	Battery (show the SOC in five grid, Every grid represents 20%)
H	Local load
I	Wireless communication
J	RS232
K	RS485
L	Buzzer(Reserved)
M	Warning
N	Fault

6.4.2 LED and button instruction

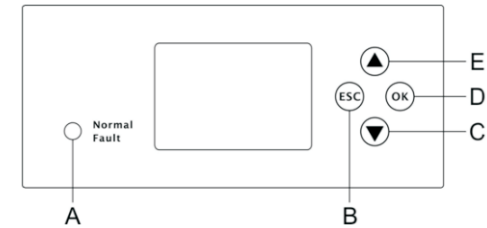

Chart 6.3

Location	Description
A	Status
B	ESC- button(cancel control)
C	Down-button
D	Enter-button
E	UP-button

Notice:

LED showing status of SPH, it has two colors, one is green and another is red. Please turn to 3.1 and read the detail of LED.

6.4.3 LCD display column

LCD display column is used to show the current state, basic information and fault information. Also includes language setting, program charging/discharging priority and system time. On default condition will take turns to display the information.

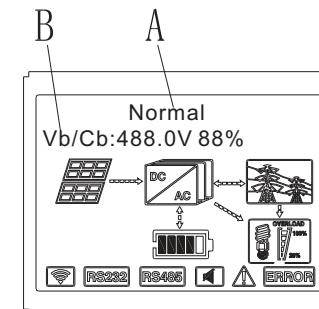

Chart 6.4

The A line's concluding information as follow:

- Standby state: SPH is in standby state. No error in this state, but for other reasons, make it in a wait state.
- Normal state: SPH is normal working state.
- Checking state: SPH is in self-check state, if there is no error or warning, SPH will go to normal state or standby state. Otherwise it will go to fault state.
- Programming state: SPH is in updating firmware state.
- Fault state: SPH has fault information, it will be in stopped operational protection state.

The B line's information as follow:

In normal, it will turn on page automatically, when pushing the button "UP", the order of the paging information as follow:

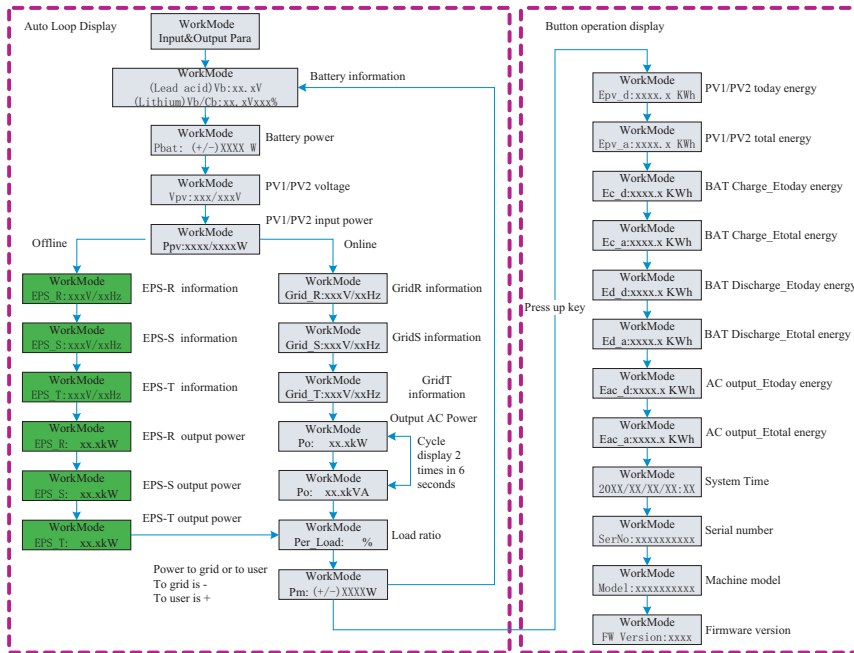

Chart 6.5

Note:

- "Down" control command (if pushing "up" button, command will go back).
- Workmode depend on the situation. If SPH is normal state, it will show "normal". If SPH is standby state, it will show as "standby" etc.
- Some special definitions are explained, for example: Vb means the voltage of battery. Cb means the capacity of lithium battery (only lithium battery shows this data). Pm means the monitor power of user.

6.4.4 work mode set up

Keep pressing "enter" for 3S, you can enter set up surface, in the set up surface you need hold button Enter or ESC 1S for selection, you can see the surface as showing below.

Press "enter" key more than 3 seconds into setup mode

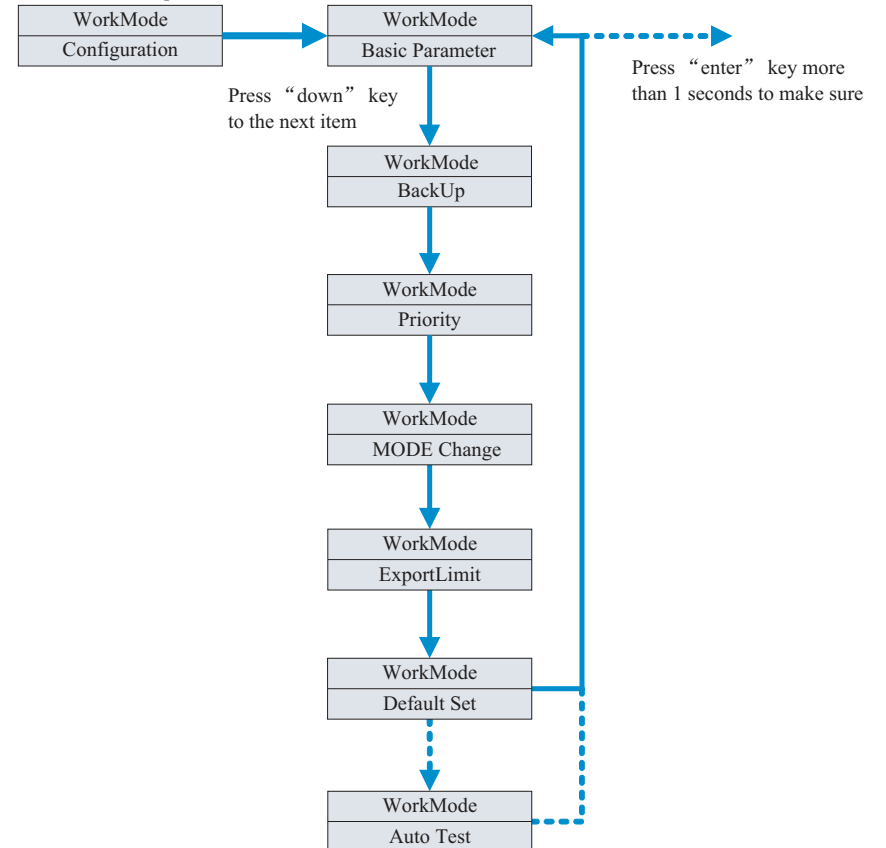

Chart 6.6

If you choose CEI and used SPH inverter in Italy, SPH inverter have Auto Test function. How to use the Autotest functions. Please see the annex.

1. Under the Basic Para, you can see the setup options below after pressing Enter for 1S:

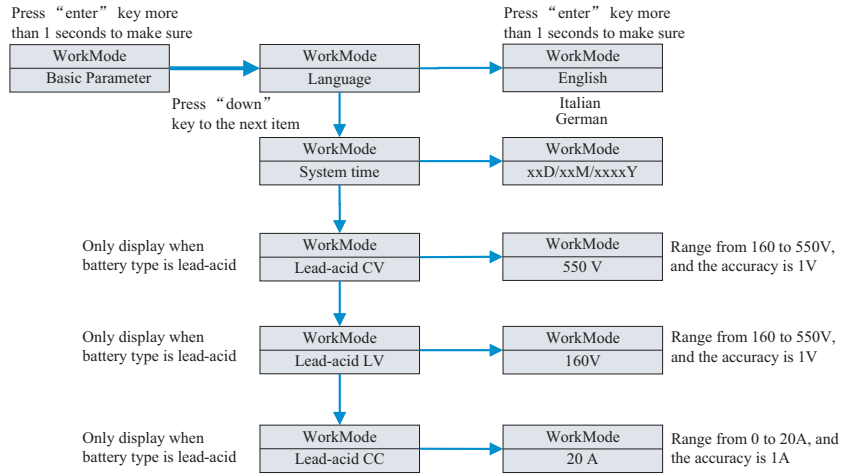

Chart 6.7

In the basic Parameter, you can set language (English, Italian, German), system time, Lead-acid CV(default is 550V), Lead-acid LV(default is 160V)Lead-acid CC(default is 20A).

2. Under the Back Up, you can see the setup options below after pressing Enter for 1S:

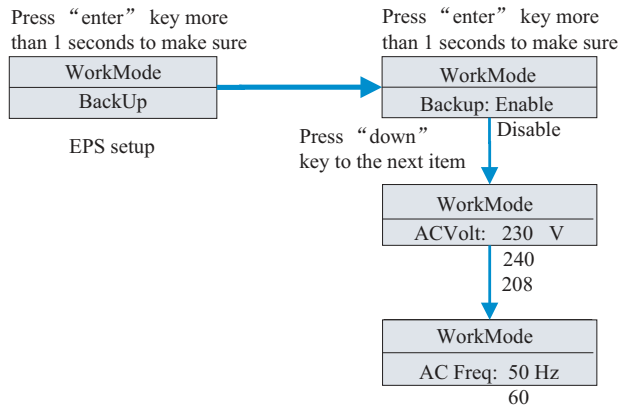

Chart 6.8

In the back up you can set EPS, including enable or disable (default is enable), AC voltage(default is 230V) and frequency (default site 50HZ).

3. Under the Priority, you can see the setup options below after pressing Enter:

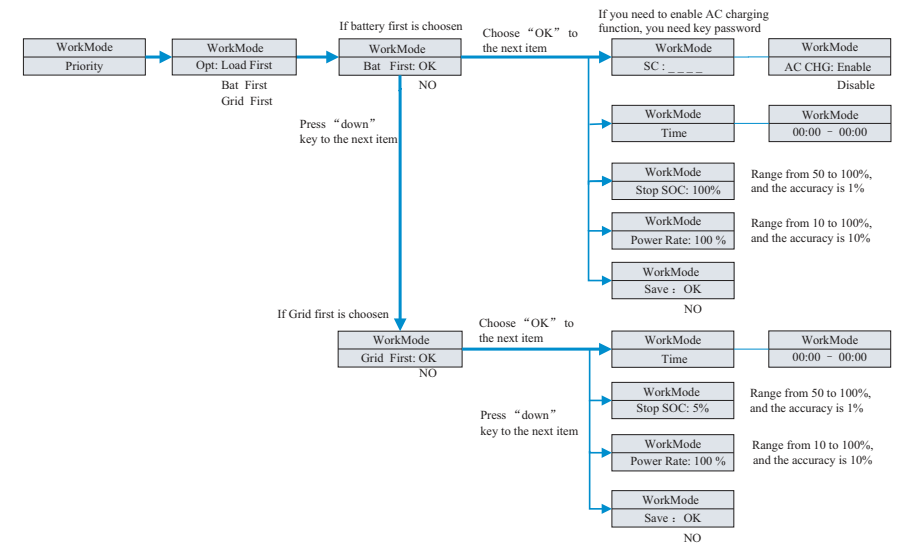

Chart 6.9

Note:

- “Power Rate” is used to set up power of battery. So different battery may have the different power, customer need to check the max power of battery.
- Time setting is 24-hour. If the end time is less than beginning time, it defaults to spanning days.

4. Under the MODE Change, you can see the setup options below after pressing Enter:

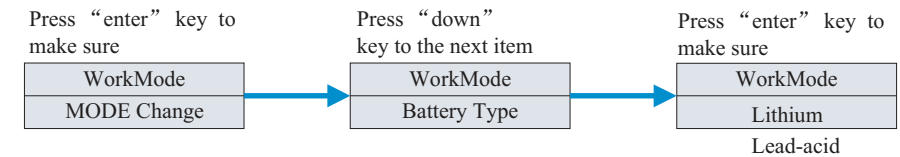

Chart 6.10

The MODE change has two options what are sensor and battery type, sensor is meter(default) .In the battery type, you can choose lithium battery or lead-acid battery.

5. Under the Export Limit, you can see the setup options below after pressing Enter:

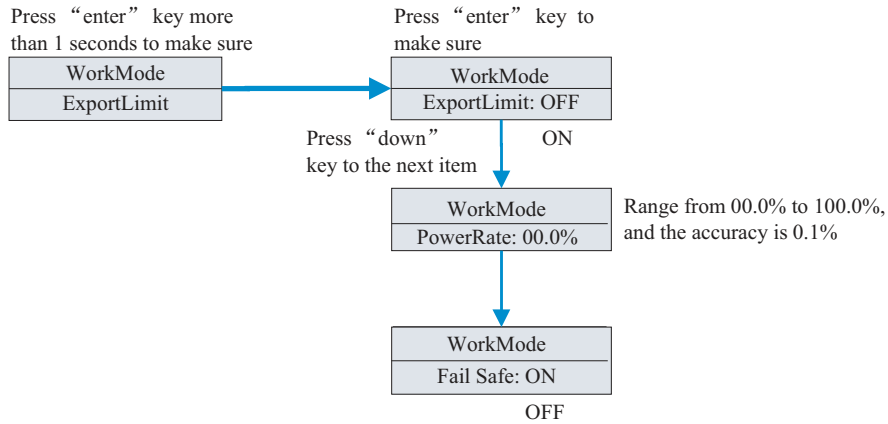

Chart 6.11

Export Limit is used for users to control the energy flowing to the grid. If this function is enabled, the feeding power to grid will be equal or less than the setup value. The purpose of the Fail Safe function is to ensure that should any part of the ELS fail, the Active Power exported across the Connection Point will drop to the Agreed Export Capacity or less within the specified time.

- Note:**
- Default value is 00.0%.

6. Under the default set, you can see the setup options below after pressing Enter:

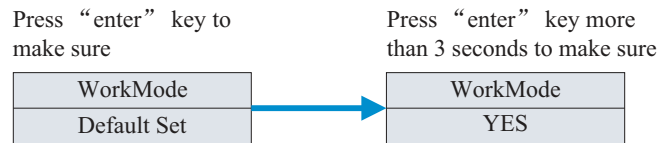

Chart 6.12

Default set is "resume to default setting", please don't use it unless it's necessary.

6.5 Communication

6.5.1 Use of USB-A port

USB-A port is mainly for firmware update. Through USB connection, we can quickly update the software of machine. You can see USB-A as below:

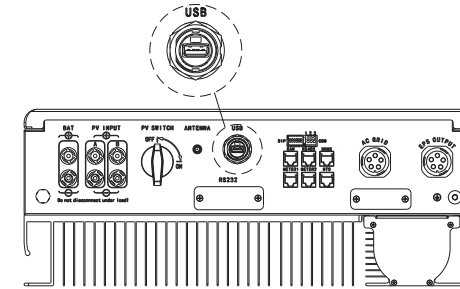

Chart 6.13

Note: USB is only used for firmware update. Customer can't use it for charging.

6.5.2 Use of RS232 port

RS232 port is mainly used for monitoring connection with computer, users can monitor, set parameters and update the software of the machine through RS232 connection with machine and PC, using the shinebus software developed by Growatt. About ShineBus software, when you needed, please download from official website of Growatt.



Chart 6.14

Before use RS232 communication, you should make sure the follow PIN1 and PIN2 are off:

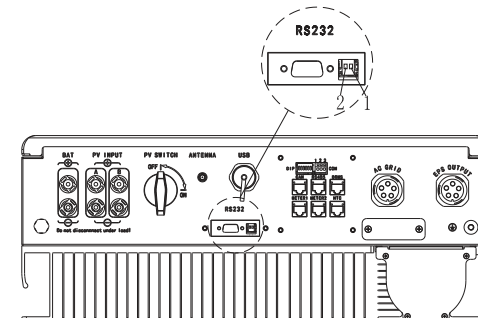

Chart 6.15

Start-up and shut down SPH system 7

The wiring diagram is as follows:

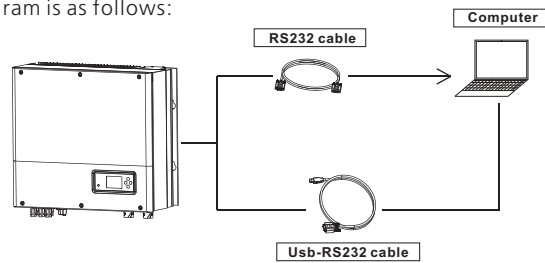

Chart 6.16

6.5.3 The SPH's monitoring

The SPH provide RS232 interface. Users can through the following communication solution to monitor the SPH.

Note:

This kind of monitoring can only be used by the monitor of Growatt's Shineserver /shine phone provided by the company. Through RS232 interface connect to Wi-Fi-S/Shinelink, use computer terminal/or mobile phone for data monitoring.

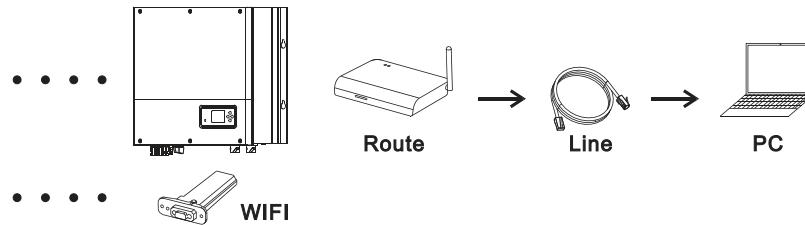

Chart 6.17

Before use WIFI communication, you should make sure the follow PIN1 and PIN2 are ON:

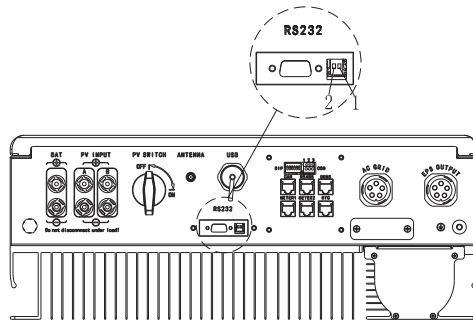

Chart 6.18

7.1 Start-up the SPH system

Users can start-up SPH inverters through following steps:

1. Connect to PV.
2. Connect to Grid.
3. Connect to Battery.
4. Turn the switch on in turn of Grid, battery and PV.
5. When the LED turns green, the working information on LCD indicates the successful start-up of SPH inverter.

7.2 Disconnect the SPH system

1. Turn off all the circuit breaker and switch.
2. Disconnect PV.
3. Disconnect the inverter.
4. Disconnect the battery.
5. Pull up AC PLUG connection.
6. Waiting until LED, LCD display have gone out, the SPH is shut down completely.

8 Attention of the installation environment, maintenance and cleaning

Heat dissipation performance is very important when SPH inverter work under the environment of high temperature, better heat dissipation can reduce the possibility of SPH inverter stops working. Growatt SPH series inverter without fan so belongs to natural cooling, hot air from the top of the radiator, tie-in battery, use environment for IP65, please pay attention to the temperature of the installation environment, to ensure that the battery's safety and the normal work of the machine.

When use battery, please pay attention to the follow information:

Caution: Do not dispose of batteries in a fire. The batteries may explode.

Caution: Do not open or damage batteries. Released electrolyte is harmful to the skin and eyes. It may be toxic.

Caution: A battery can present a risk of electrical shock and high short-circuit current.

The following precautions should be observed when working on batteries:

- ve watches, rings or other metal objects.
- Use tools with insulated handles.
- Wear rubber gloves and boots.
- Do not lay tools or metal parts on top of batteries.
- Disconnect charging source prior to connecting or disconnecting battery terminals.
- Determine if battery is inadvertently grounded. If inadvertently grounded, remove source from ground. Contact with any part of a grounded battery can result in electrical shock. The likelihood of such shock can be reduced if such grounds are removed during installation and maintenance(applicable to equipment and remote battery supplies not having a grounded supply circuit).

If SPH inverter doesn't work for overheating or too cold, solve it according to the following methods:

- Confirm whether the radiator air duct installation is reasonable, choose the appropriate position before installation.
- If lead-acid batteries are connected, confirming the NTC battery is in a good installation.
- Confirm whether the battery temperature is too high, too high temperature of battery can also lead to SPH fail to work, at this point, to ventilation, cooling or still handle to the battery, please.
- If temperature is low, also can appear the battery low temperature protection, the battery will start with small load in low temperature output, after temperature back to normal system can work normally, please be patient at this time.
- If the temperature is too low, it is possible that battery will be low temperature protection, at this time, please pay attention to the working temperature range listed in the specifications of the book.
- Servicing of batteries should be performed or supervised by personnel knowledgeable about batteries and the required precautions.
- When replacing batteries, replace with the same type and number of batteries or battery packs.
- General instructions regarding removal and installation of batteries.

Remark:

All of above action should be operated by professional person, if you want to do these works, you must make sure the whole system are off.

Fault removal 9

Our products are carried out with strict tests before they take out, if the operation difficulties in the process of installation, please log on to www.ginverter.com website, view the Q&A program.

When SPH inverter fault happens, please inform our company, and to provide SPH related information, we will have a professional after-sales service personnel to answer you.

What you need to provide the information about the SPH including:

- Serial number.
- Model.
- Information about the LCD display.
- Brief description of problems.
- The battery voltage.
- The PV input voltage and power per string.
- The grid voltage and frequency.
- Can you retell the failure problem? If you can, what kind of a situation.
- Did the problem happen in the past?
- When did this fault happen? First installation?

About the battery:

- The manufacturer name and model of battery.
- Capacity of battery.
- Output voltage of the battery.
- The time you buy Battery and frequency you use it.

9.1 System fault information list and troubleshooting suggestions

Warning Message		
Error message	Description	Suggestion
Warning401	Meter Communication fault	Check the wire connection between meter and inverter is good or not.
Warning203	Pv1 or PV2 Circuit short	1. Check the positive and negative of PV input is reversed or not. 2. Reinserted the PV terminal, please contact Growatt service center if restart can't solve the problem.
Warning506	Battery temperature out of specified range for charge or discharge	Check the environment temperature of battery is in the range of specification or not.

AC V Outrange	Grid voltage fault. Please refer to the local grid standard for more details of the grid frequency.	1.Check the AC voltage is in the range of standard voltage in specification. 2.Check the grid connection is good or not.
AC F Outrange	Grid frequency fault. Please refer to the local grid standard for more details for the grid voltage.	1.Check the frequency is in the range of specification or not. 2.Restart inverter. 3.Please contact Growatt service center if restart can't solve the problem.
BMS COM Fault	Communication fault	1.Check the lithium Battery is open or not. 2.Check the connection of lithium Battery and inverter is good or not.
Battery reversed	Battery terminals reversed	Check the positive and negative of battery is reversed or not.
BAT NTC Open	NTC open (only for lead-acid battery)	1.Check the temperature of lead-acid battery is installed or not. 2.Check the temperature of lead-acid battery is connected well or not.
Battery Open	Battery terminal open (only for lithium battery)	1.Check the battery connection is good or not. 2.Check the switches between the battery and inverter are all on or not.
Over load	EPS output overload warning. If this warning occurred three time. Off-grid function will be locked one hour and output power again.	Please reduce the load of EPS output.
No AC Connection	No Utility	1.Please confirm grid is lost or not. 2.Check the grid connection is good or not. 3.Check the switches on the cable are on or not.
Output High DCI	Output DC current too high. Please refer to the local grid standard for disconnection time when the output DC current is too high.	1.Restart inverter. 2.Please contact Growatt service center if restart can't solve the problem.

Bat Voltage High	Battery Voltage higher than 560V	1.Check the voltage of battery is in the range of specification or not. 2.Check the battery connection is right or not If battery is really higher than 560V. Please disconnect the connection of battery and check inverter.
Bat Voltage Low	Battery Voltage Lower than 150 V	1.Check the real voltage of battery. 2.Check the wire of battery and inverter is good or not.
BMS Warning:XXX	BMS report warning	1.Check the warning information from lithium battery user manual. 2.Please contact Growatt service center if restart can't solve the problem.
BMS error:XXX	BMS report error	1.Check the warning information from lithium battery user manual. 2.Please contact Growatt service center if restart can't solve the problem.
EPS Volt Low	EPS output voltage low	1.Check the load of EPS. If overload occurred, reduce load. 2.Restart inverter again.

Error message		
Error message	Description	Suggestion
Error 411	Internal communication failed	1.Restart inverter. 2.Please contact Growatt service center if restart can't solve the problem.
Error 418	DSP and COM firmware version unmatch, system fault.	1.Read DSP and COM firmware version from LCD or shinebus. 2.Check if the firmware is correct.
Error 303	Inverter L N reversed or ground failed	1.Check the connection of PV panels and inverter is good or not. 2.Check the PE of inverter is good or not.
Error 405	Relay fault	1.Restart inverter. 2.Please contact Growatt service center if restart can't solve the problem.

Error 407	Autotest failed (only in Italy)	1.Restart inverter. 2.Please contact Growatt service center if restart can't solve the problem.
PV Isolation Low	PV isolation too low	1.Check the connection of PV panels and inverter is good or not. 2.Check the PE of inverter is good or not.
OP Short Fault	EPS Output Short Fault	1.Check the load of EPS. 2.Check the output of EPS. Especially not connect to grid.
NTC Open	Internal temperature failed	Please contact Growatt service center
Error 406	Model set up not meet with certification	Please check model set or check the DIP setting
Residual I High	Leakage current too high	1.Check the cable of inverter. 2.Restart inverter. 3.Please contact Growatt service center if restart can't solve the problem.
Error 408	Temperature over range	Please check the temperature is in the range of specification or not.
PV Voltage High	PV voltage higher than datasheet	Please check the voltage of PV input is in the range of specification or not.

10 EU Declaration of Conformity

With the scope of EU directives:

- 2014/35/EU Low Voltage Directive (LVD)
- 2014/30/EU Electromagnetic Compatibility Directive (EMC)
- 2011/65/EU RoHS Directive and its amendment (EU)2015/863

Shenzhen Growatt New Energy Technology Co. Ltd confirms that the Growatt inverters and accessories described in this document are in compliance with the above mentioned EU directives. The entire EU Declaration of Conformity can be found at www.ginverter.com.

11.1 Dismantling the energy storage

- 1.Disconnect the SPH inverter such as mentioned in section 7.
- 2.Disconnect the upper cable of SPH inverter.



Watch out the SPH's shell heat and prevent to scald
Wait 20 minutes until the SPH cooling and then to disassembly!

- 3.Unscrew all the connecting cable.
- 4.Unscrew the radiator and wall-mounted anchor screw and then take down the machine from wall.

11.2 Packing the SPH inverter

Usually placed SPH inverter in the packing box with tape sealing, If the SPH inverter cannot reoccupy, You can choose a cheap carton for packaging. Carton requirements must meet the size of the inverter and can support energy storage machine overall weight.

11.3 Storing SPH inverter

Store SPH inverter in a dry place where ambient temperatures are always between -25°C and +60°C.

11.4 Disposing of the SPH inverter



Do not dispose of SPH inverter together with household waste. Please accordance with the disposal regulations for electronic waste which apply at the installation site at that time. Ensure that the old unit and, where applicable, any accessories are disposed of in a proper manner.

12 Product specification

12.1 Growatt SPH series energy storage machine product specification

Model	SPH 4000 TI3 BH	SPH 5000 TI3 BH	SPH 6000 TI3 BH	SPH 7000 TI3 BH	SPH 8000 TI3 BH	SPH 10000 TI3 BH
Specifications						
Input data(DC)						
Max. recommended PV power(for module STC)	5200W	6500W	7800W	9100W	10400W	13000W
Max. DC voltage	1000V	1000V	1000V	1000V	1000V	1000V
Start voltage	160V	160V	160V	160V	160V	160V
Nominal voltage	600V	600V	600V	600V	600V	600V
MPP voltage range	160~1000V	160~1000V	160~1000V	160~1000V	160~1000V	160~1000V
No. of MPP trackers	2	2	2	2	2	2
No. of PV strings per MPP trackers	1	1	1	1	1	1
Max. input current per MPP	12A/12A	12A/12A	12A/12A	12A/12A	12A/12A	12A/12A
Max. short-circuit current per MPP trackers	15A/15A	15A/15A	15A/15A	15A/15A	15A/15A	15A/15A
Output data(AC)						
AC nominal power	4000W	5000W	6000W	7000W	8000W	10000W
Max. AC apparent power	4000VA	5000VA	6000VA	7000VA	8000VA	10000VA
Nominal AC voltage/range	230V/400V; 310~476V					
AC grid frequency/range	50/60Hz; 45~55Hz/55~65 Hz					
Max. output current	6.1A	7.6A	9.1A	10.6A	12.1A	15.2A
Power factor(@nominal power)	1					
Adjustable power factor	0.8leading ~ 0.8laging					
THDi	<3%					
AC grid connection type	3W+N+PE					
Stand alone(AC power)						
AC nominal output power	4000W	5000W	6000W	6000W	6000W	6000W
Max. AC apparent power	4000VA	5000VA	6000VA	6000VA	6000VA	6000VA
Nominal AC voltage	230V/400V					
Nominal AC frequency	50/60Hz					
Max. output current	6.1A	7.6A	9.1A	9.1A	9.1A	9.1A

THDV	< 3%					
Switch time	< 0.5S					
Battery data (DC)						
Battery voltage range	160~550V					
Recommended battery voltage	200V	250V	300V	350V	400V	500V
Max. charging / discharging current	20A					
Continuous charging / discharging power	4000W	5000W	6000W	7000W	8000W	10000W
Type of battery	lithium battery / Lead-acid battery					
Capacity of battery	5~50kWh					
Efficiency						
Max. efficiency	97.6%	97.8%	98.0%	98.2%	98.2%	98.2%
Euro-eta	97.0%	97.2%	97.3%	97.4%	97.4%	97.5%
MAX. Battery charge/discharge efficiency	97.4%	97.4%	97.4%	97.4%	97.4%	97.4%
Protection devices						
DC reverse-polarity protection	yes	yes	yes	yes	yes	yes
Battery reverse protection	yes	yes	yes	yes	yes	yes
DC switch	yes	yes	yes	yes	yes	yes
DC Surge protection	Type II	Type II	Type II	Type II	Type II	Type II
Insulation resistance monitoring	yes	yes	yes	yes	yes	yes
AC surge protection	Type II	Type II	Type II	Type II	Type II	Type II
AC short-circuit protection	yes	yes	yes	yes	yes	yes
Ground fault monitoring	yes	yes	yes	yes	yes	yes
Grid monitoring	yes	yes	yes	yes	yes	yes
Anti-islanding protection	yes	yes	yes	yes	yes	yes
Residual-current monitoring unit	yes	yes	yes	yes	yes	yes
General data						
Dimensions (W / H / D)	505*453*198mm					
Weight	28kg					
Operating temperature range	- 25 °C ~ +60 °C(-13 °F ~ +140 °F) With derating above 45 °C(113 °F)					

Noise emission (typical)	≤ 35 dB(A)
Altitude	4000m
Self-Consumption	<7W
Topology	Transformerless
Cooling	Natural
Protection degree	IP65
Relative humidity	0~100%
DC connection	H4 / MC4 (optional)
AC connection	Cable gland+OT terminal
Battery connection	H4 / MC4 (optional)
Interfaces	
Display	LCD+LED
RS232/RS485/CAN/USB	yes
RF/WIFI/GPRS/4G	optional
Warranty: 5 / 10 years	yes / optional
Certificates and approvals	
Grid regulation	IEC 62040, VDE-AR-N 4105, VDE 0126, UTE C 15-712, EN50438, TR3.2.1, TR3.3.1, CEI 0-21, IEC62116, IEC61727, AS/NZS 4777, G98
EMC	EN61000-6-1, EN61000-6-3
Safety	IEC/EN62109-1, IEC/EN62109-2

12.2 DC input terminal parameter

Mc4 specification:

	2.5mm ² /14AWG	4mm ² /12 AWG	6mm ² /10 AWG	10mm ² /8AWG
Rated current (90°C environment)	32A	40A	44A	65A
Nominal system voltage	1000V DC(UL) 1000V DC(TUV)			
Contact resistance	0.25mΩ (model)			
Protection grade	IP68			

Socket contact materials	Copper, tin
Insulation materials	Thermoplastics UL94 V-0
Ambient temperature range	-40°C to +90°C
Wire stripping length	7.0mm(9/32)
Cable casing diameter	4.5 to 7.8mm(3/16: to 5/16")

12.3 Torque

Upper cover screws	1.3Nm(10.8 1bf.in)
Shell and RS232screws	0.7Nm(6.2 1bf.in)
Dc connector	1.8Nm(16.0 1bf.in)
M6 screwdriver	2Nm(18 1bf.in)
Grounding screw	2Nm(18 1bf.in)

12.4 Appendix

The following chart is the energy storage machine optional appendix list, if there is a need please contact the Growatt New Energy Technology Co., Ltd or dealer orders.(P/N is only for reference,and it may be changed)

Name	Description	GROWATT P/N
Shine link	Used for data record in EU	MR00.0007200
	Used for data record in Australia	MR00.0006100
Shine Wi-Fi	COM interface	MR00.0004601
Shine 3G	COM interface	MR00.0004700

13 Certificate

Growatt SPH series inverter apply within the scope of the world, So the inverter have to satisfy different countries and regions of different safety standards.

Model	Certificate
Growatt-SPH series	IEC 62040, VDE-AR-N 4105, VDE 0126, UTE C 15-712, EN50438, TR3.2.1, TR3.3.1, CEI 0-21, IEC62116, IEC61727, AS/NZS 4777, G98, EN61000-6-1, EN61000-6-3, IEC/EN62109-1, IEC/EN62109-2

14 Contact

If you have technical problems about our products, contact the Growatt Service line or dealer. We need the following information in order to provide you with the necessary assistance:

- 1.SP H inverter Serial number.
- 2.SP H inverter module information.
- 3.SP H inverter communication mode.
- 4.SP H inverter fault information code.
- 5.SP H inverter Display content.
- 6.The manufacturer and model of the battery.
- 7.Battery capacity and connection mode.

GROWATT NEW ENERGY TECHNOLOGY Co.,LTD

- No.28 Guangming Road, Longteng Community, Shiy an,
- Bao'an District, Shenzhen, P.R.China
- www.ginverter.com
- Serviceline
- Tel: + 86 755 2747 1942
- Email: service@ginverter.com

Annex:

AutoTest (only for Italy)

Follow is the chart of Auto Test, refer to 6.4.4. in the set up surface of "Auto Test". Press the "enter" key, make sure to start auto test by press "enter" key 3 seconds. The LCD will display the follow message.

